

技术参数 SPECIFICATIONS

- 线数 (Poles) : 2~15
- 适用线规 (Applicable wires) : AWG28#~22#
- 适应基板厚度 (Applicable PC board thickness) : 1.6mm
- 温度范围 (Temperature range) : -25℃~85℃
- 额定电压 (Voltage rating) : 250V.Ac/Dc
- 额定电流 (Current rating) : 3A
- 接触电阻 (Contact resistance) : $\leq 0.02\Omega$
- 绝缘电阻 (Insulation resistance) : $\geq 1000M\Omega$
- 耐压 (Withstand voltage) : 1000V.Ac/1min
- 材料 (Material) :
 - 插头 (Plug housing) : 尼龙 (PA66) UL94V-2(0)
 - 插座 (Receptacle housing) : 尼龙 (PA66) UL94V-2(0)
 - 针座 (Wafer) : 尼龙 (PA66) UL94V-2(0)
 - 端子 (Terminal) : 磷青铜 (Phos.bronze Tin/plated)

端子 TERMINAL (YST200/YDT200)

型号 Type	适用线规 Applicable wires		电线外径 O.D of wire ins mm	数量 Quantity
	mm ²	AWG#		
HX20012-PT	0.08~0.33	28~22	1.0~1.5	12000PCS/盘
HX20020-RT	0.08~0.33	28~22	1.0~1.5	10000PCS/盘

HX20012-PT (YST200)

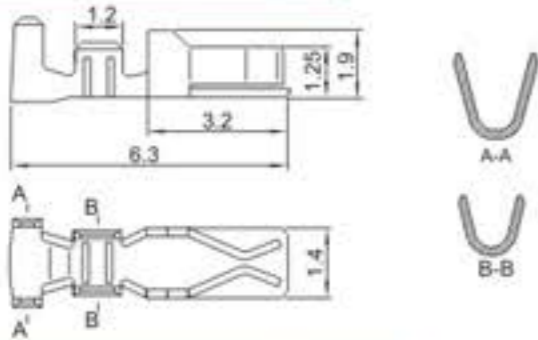

HX20020-P (SMH200/HY)

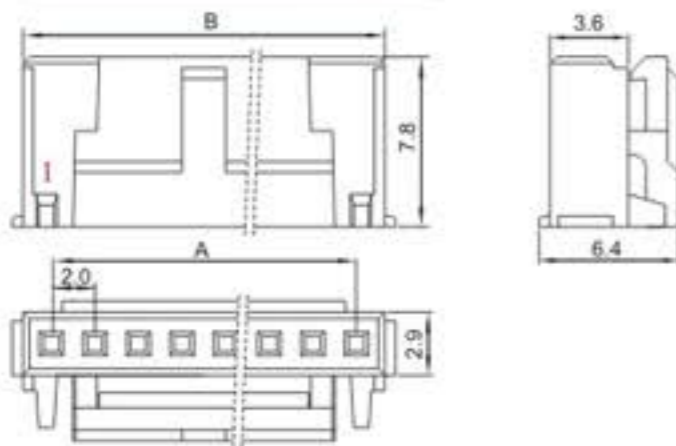

HX20020-RT (YDT200)

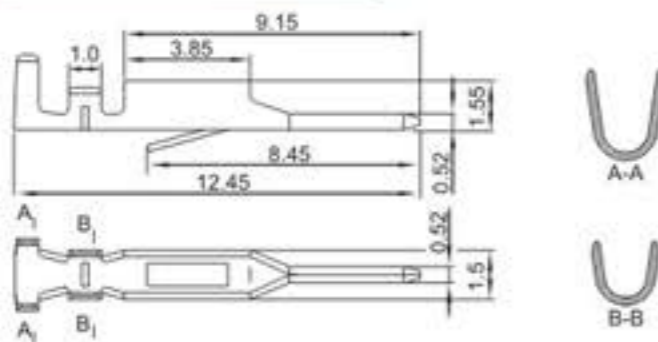

HX20020-R (SMH200-PL/HY)

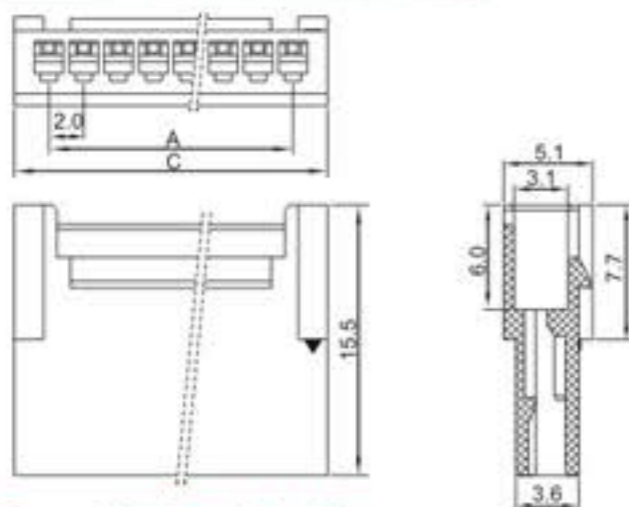

HX20020-A (SMW200/HY)

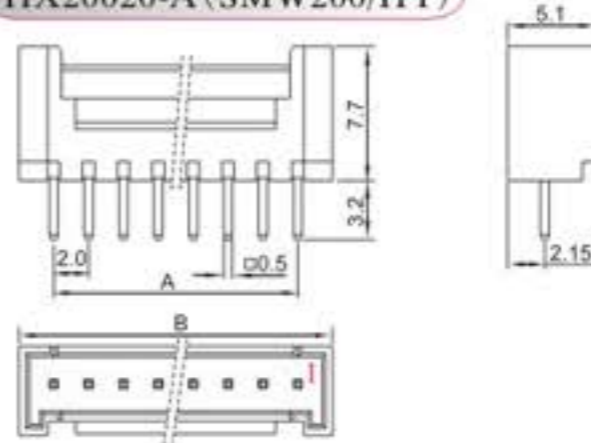

HX20020-WA (SMAW200/HY)

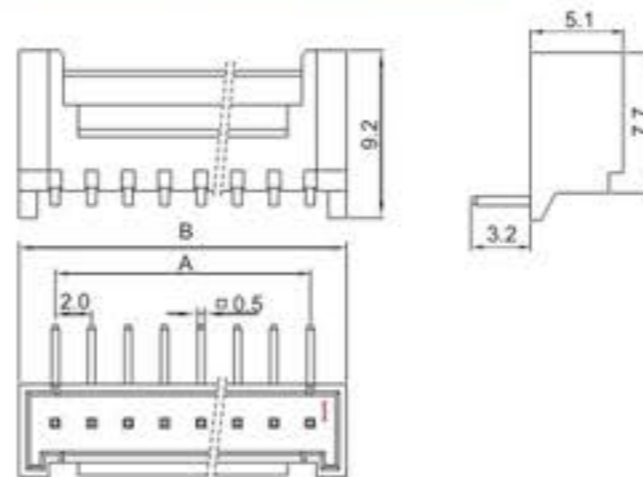

安装尺寸 MOUNTING MEASUREMENT

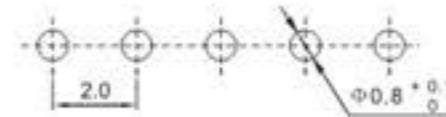

插头座 HOCSING (SMH200/SMH200-PL)

线数 Poles	型号 Type	尺寸Dimensions(mm)		
		A	B	C
2	HX20020-2P/R	2.0	4.6	5.98
3	HX20020-3P/R	4.0	6.6	7.98
4	HX20020-4P/R	6.0	8.6	9.98
5	HX20020-5P/R	8.0	10.6	11.98
6	HX20020-6P/R	10.0	12.6	13.98
7	HX20020-7P/R	12.0	14.6	15.98
8	HX20020-8P/R	14.0	16.6	17.98
9	HX20020-9P/R	16.0	18.6	19.98
10	HX20020-10P/R	18.0	20.6	21.98
11	HX20020-11P/R	20.0	22.6	23.98
12	HX20020-12P/R	22.0	24.6	25.98
13	HX20020-13P/R	24.0	26.6	27.98
14	HX20020-14P/R	26.0	28.6	29.98
15	HX20020-15P/R	28.0	30.6	31.98

针座 WAFER (SMW200/SMAW200)

线数 Poles	型号 Type	尺寸Dimensions(mm)	
		A	B
2	HX20020-2A/WA	2.0	5.98
3	HX20020-3A/WA	4.0	7.98
4	HX20020-4A/WA	6.0	9.98
5	HX20020-5A/WA	8.0	11.98
6	HX20020-6A/WA	10.0	13.98
7	HX20020-7A/WA	12.0	15.98
8	HX20020-8A/WA	14.0	17.98
9	HX20020-9A/WA	16.0	19.98
10	HX20020-10A/WA	18.0	21.98
11	HX20020-11A/WA	20.0	23.98
12	HX20020-12A/WA	22.0	25.98
13	HX20020-13A/WA	24.0	27.98
14	HX20020-14A/WA	26.0	29.98
15	HX20020-15A/WA	28.0	31.98