

Current Sensor

Product Series: STK-LBS/6G

Part number: STK-100LBS/6G & STK-200LBS/6G
STK-300LBS/6G & STK-400LBS/6G
STK-500LBS/6G & STK-600LBS/6G
STK-700LBS/6G & STK-800LBS/6G
STK-900LBS/6G & STK-1000LBS/6G

Version: Ver 2.6

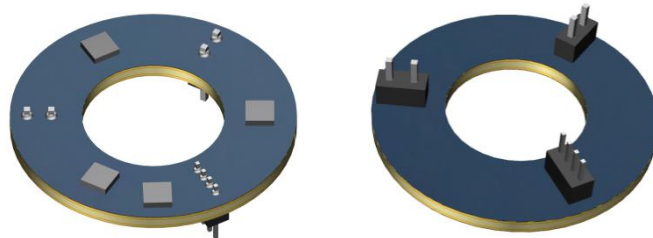

CONTENT

1.	Introduction.....	2
2.	Electrical Data.....	3
3.	Dimension & Pin Definitions.....	5
4.	Typical Application Circuit.....	6
5.	Sensor Installation.....	6

1. Introduction

The STK-LBS6 series current sensor is based on TMR (tunnel magnetoresistance) technology, and it has an open-loop design. It is suitable for DC, AC pulsed and any kind of irregular current measurement under the isolated conditions.

The STK-LBS6 current sensor is designed to measure the current of a conductive rod, which is inserted through the sensor.

Typical applications

- AC Variable speed drives
- Motor driver

General parameter

Parameter	Symbol	Unit	Value
Working temperature	T _A	°C	-40 ~ 105
Storage temperature	T _{stg}	°C	-40 ~ 125
Mass	m	g	10

Absolute maximum rating

Parameter	Symbol	Unit	Value
Supply voltage (not-destructive)	V _C	V	6
ESD rating (HBM)	U _{ESD}	kV	4

Remark: the unrecoverable damage may occur when the product works on the conditions over the absolute maximum ratings. Long-time working on the absolute maximum ratings may cause the degradation on performance and reliability.

Isolation parameter

Parameter	Symbol	Unit	Value	Comment
RMS voltage for AC test 50Hz/1 min	U _d	kV	0.5	Dependent on installation

2. Electrical Data

 Condition: $T_A = 25^\circ\text{C}$, $V_{cc} = 5\text{V}$

Parameter	Symbol	Unit	Min	Typ	Max	Comment
Primary current range	I_{PM}	A	-100		100	STK-100LBS/6G
			-200		200	STK-200LBS/6G
			-300		300	STK-300LBS/6G
			-400		400	STK-400LBS/6G
			-500		500	STK-500LBS/6G
			-600		600	STK-600LBS/6G
			-700		700	STK-700LBS/6G
			-800		800	STK-800LBS/6G
			-900		900	STK-900LBS/6G
			-1000		1000	STK-1000LBS/6G
Supply voltage	V_{cc}	V		$5 \pm 5\%$		
Current consumption	I_{cc}	mA		10		
Quiescent voltage	V_{off}	V	2.45	2.5	2.55	$V_{out} @ 0\text{A}$
Rated output voltage	V_{FS}	V		± 2		$(V_{out} @ \pm I_{PM}) - V_{off}$
Internal output resistance	R_{out}	Ω		2		V_{out}
Theoretical gain (refer remarks)	G_{th}	mV/A		20		STK-100LBS/6G
				10		STK-200LBS/6G
				6.66		STK-300LBS/6G
				5		STK-400LBS/6G
				4		STK-500LBS/6G
				3.33		STK-600LBS/6G
				2.85		STK-700LBS/6G
				2.5		STK-800LBS/6G
				2.22		STK-900LBS/6G
				2		STK-1000LBS/6G
Rated linearity error	Non-L	% I_{PM}	-1		1	$\pm I_{PM}$
Step response time	t_{res}	μs		3		@90% of I_{PM}
Delay time	t_{delay}	μs		1.5		250 kHz sine wave
Frequency bandwidth (-3dB)	BW	kHz		250		No RC circuit
Output voltage noise	V_{noise}	mVpp		20		
				30		
Accuracy @ $T_A = 25^\circ\text{C}$	X	% of I_{PM}		± 1		@ 25°C

Accuracy over T range	X_TRange	% of I _{PM}	-3.5		3.5	-40°C ~ 105°C
-----------------------	----------	----------------------	------	--	-----	---------------

Remarks:

- ✧ The theoretical gain, G_{th}, is the fitted gain when the sensor is installed with a conduct rod. The value can be obtained during the calibration process (the sensor is fixed surrounding a conduct rod).

3. Dimension & Pin Definitions

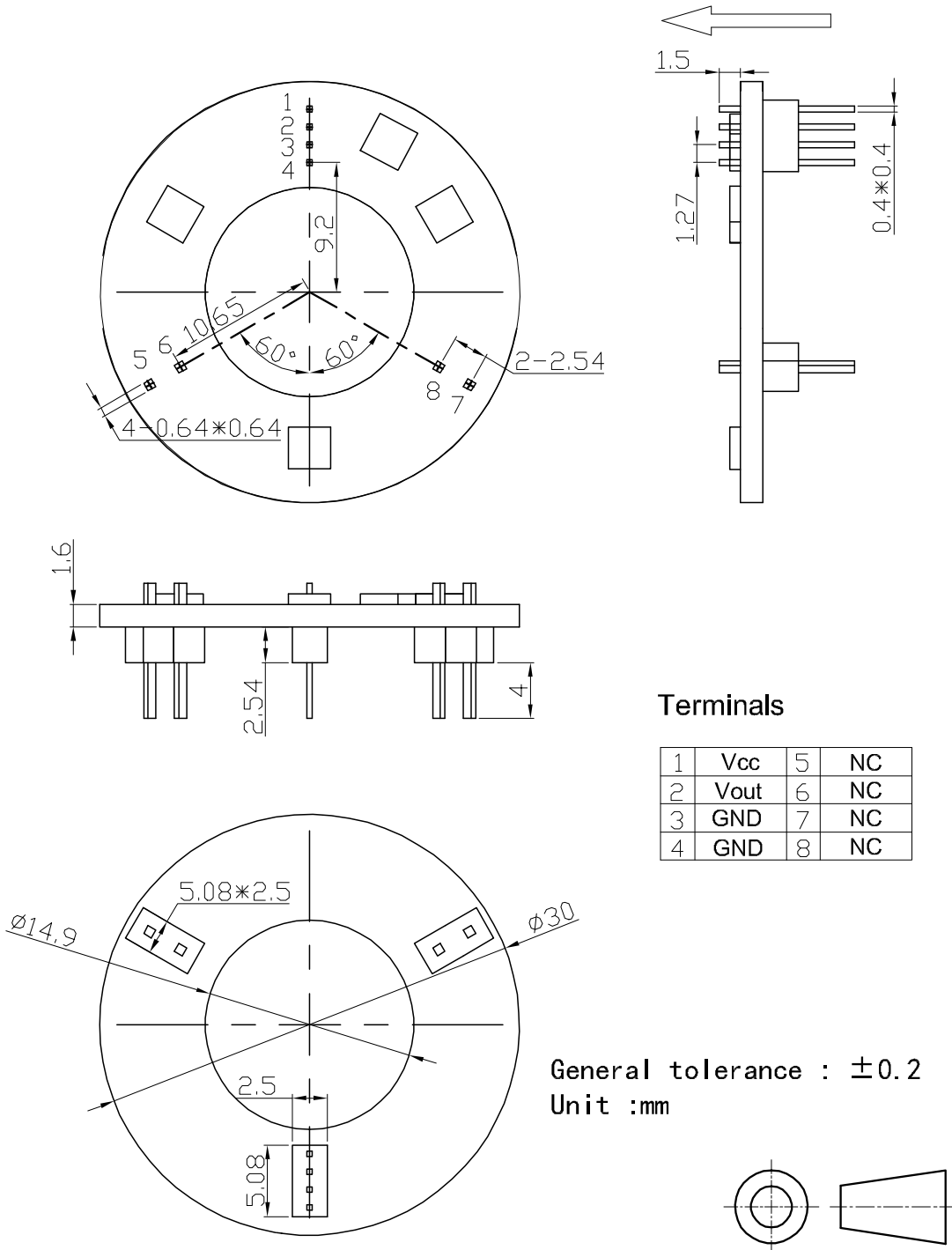

4. Typical Application Circuit

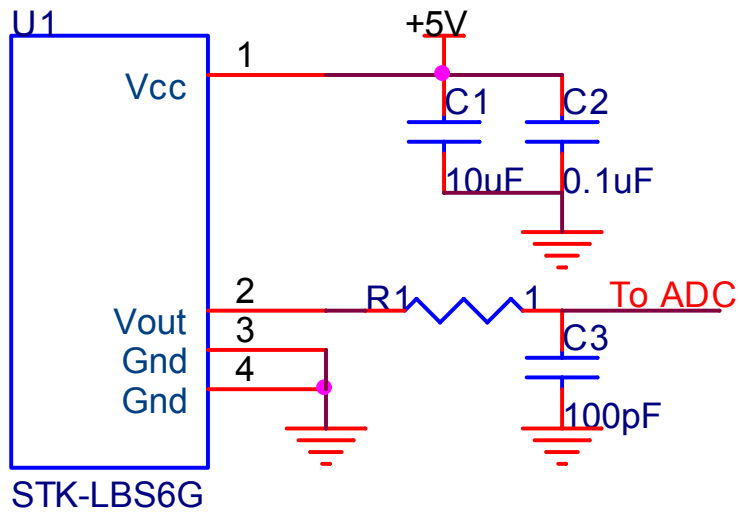

5. Sensor Installation

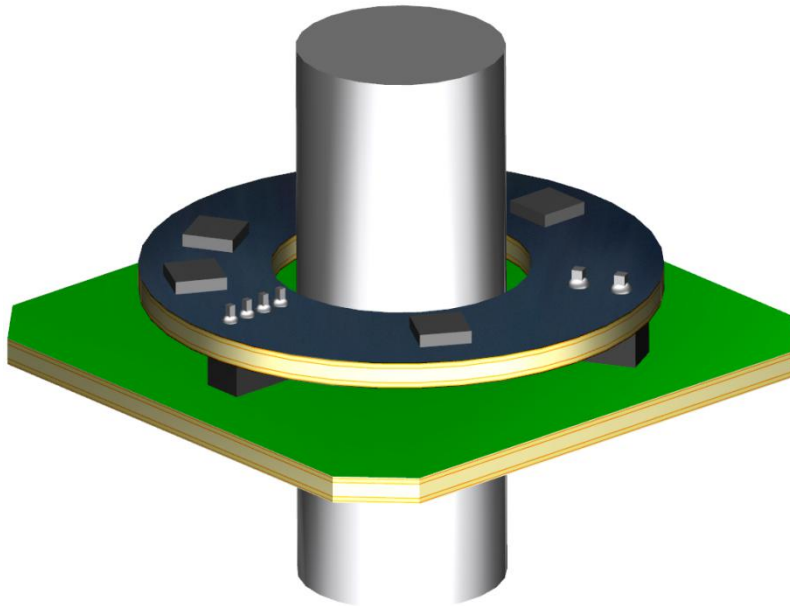

- ✧ The sensor is fixed on the user's PCB surrounding the conduct rod.
- ✧ On the holding PCB, it is recommended to put a shielding ground on the top layer (facing to the sensor) under the sensor. This is helpful to protect the signal from the dV/dt radiation.